

Use a thin sheet of paper or tissue foil of at least 15 cm square.

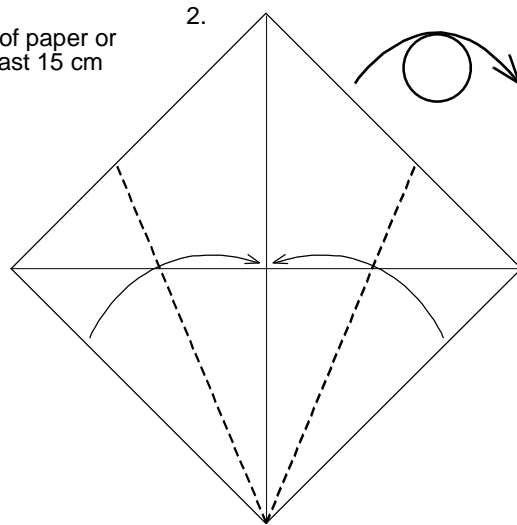

Valley fold the lower diagonal edges to the crease line in the centre and turn paper over.

Fold diagonally in half from left to right, crease well, and unfold. Repeat by folding in half from top to bottom, and unfold.

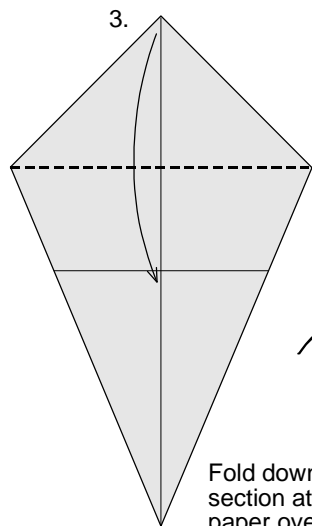

Fold down the triangular section at the top and turn paper over.

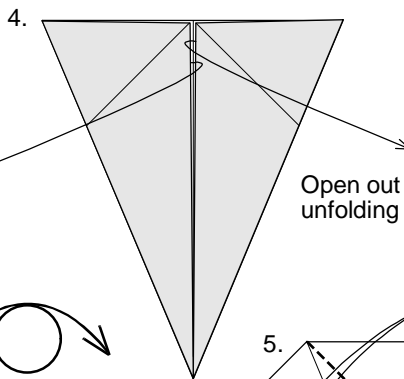

Open out to the sides, effectively unfolding Step 2.

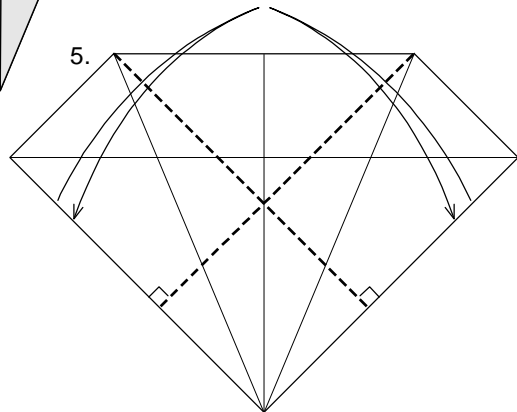
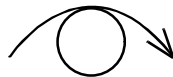

Make two diagonal folds as illustrated, in line with the edge of the triangular layer underneath. Crease firmly, and unfold.

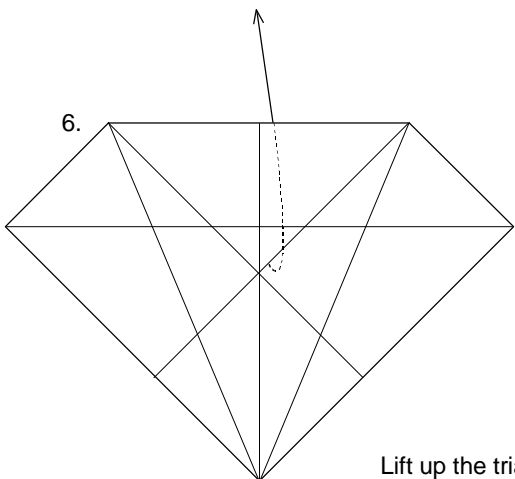

Lift up the triangular piece from behind.

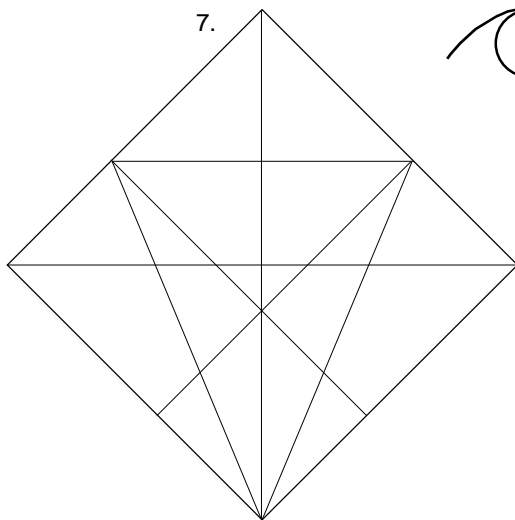

Repeat from Step 2 on the lower half of the paper, then turn the paper over.

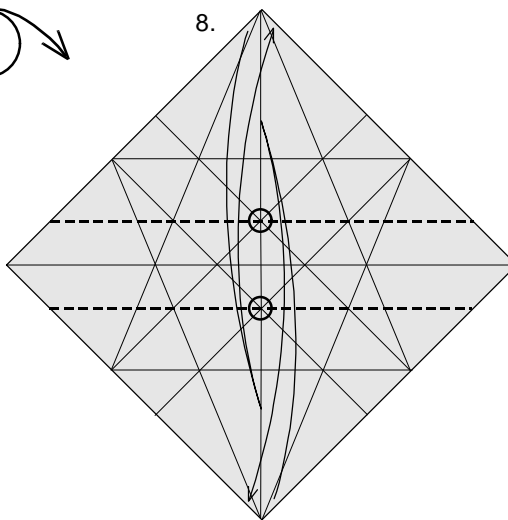
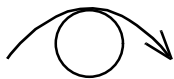

Valley fold through the circled intersecting crease lines, crease firmly, and unfold.

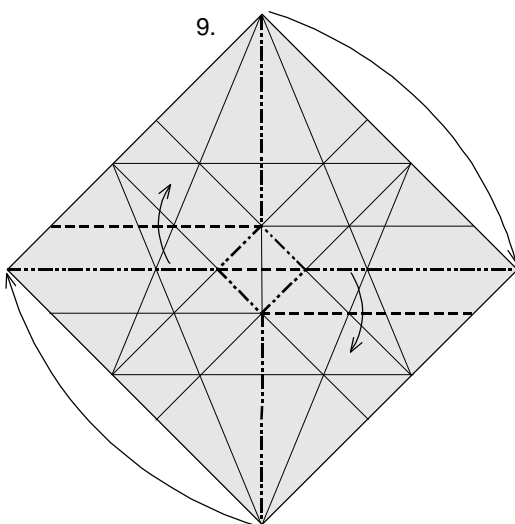

Collapse the paper along the illustrated mountain and valley folds ...

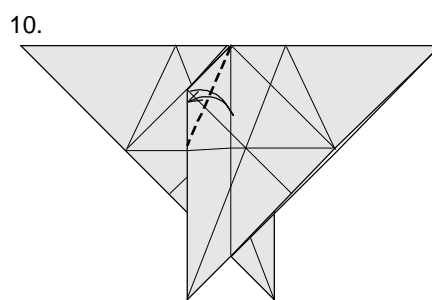

... like so. Now fold the diagonal edge in the middle to the vertical crease in the centre, crease firmly, and unfold. Repeat on the other side.

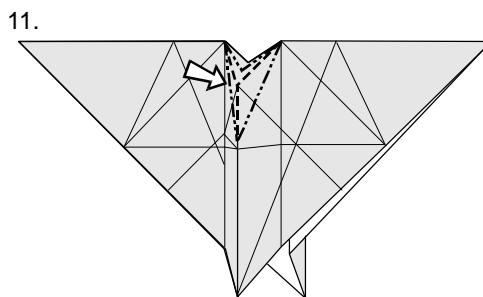

Pull the flaps on each side slightly apart and sink fold. You may need to stick a finger through the underside to guide the sink fold precisely along the crease lines made in Step 10. Repeat on the other side.

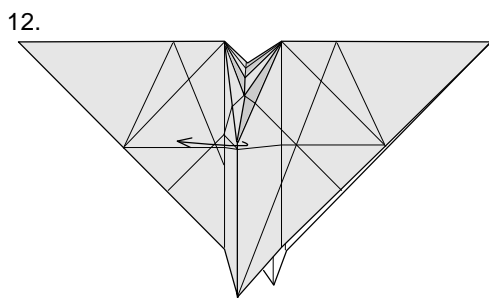

Flatten the rest of the model to the position at Step 10.

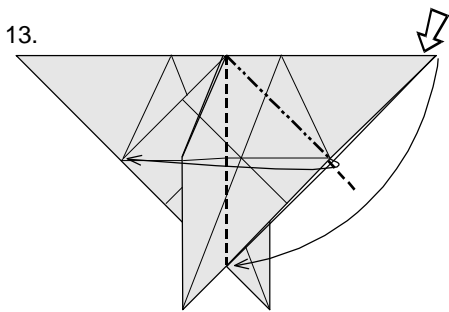

Separate the two diagonal edges on the right and squash fold. Repeat behind.

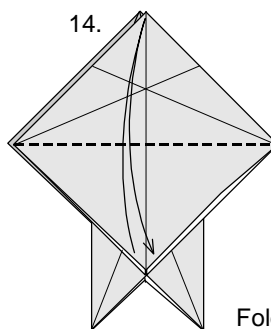

Fold the bottom corner to the top, crease well, and unfold.

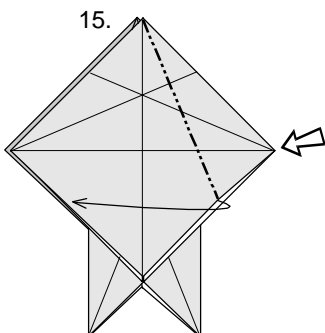

Separate the two diagonal edges and squash fold again.

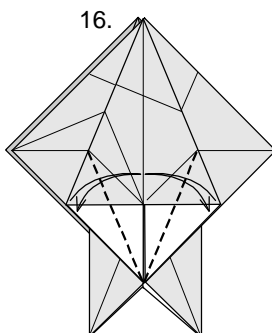

Fold and unfold, creasing firmly ...

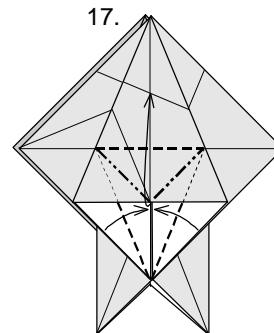

... then petal fold.

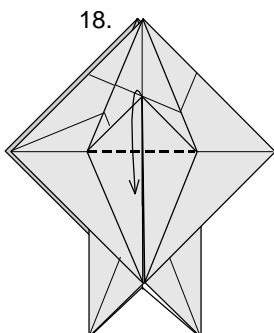

Fold the triangular flap down ...

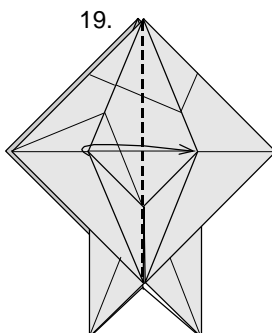

... then fold the flap on the left to the right. Repeat from Step 15 on the next flap on the left.

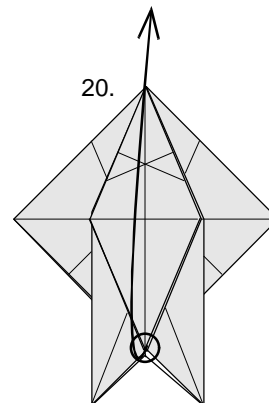

Grasp the circled point and gradually pull the flap upwards as far as it can go, opening out and flattening the layers beneath ...

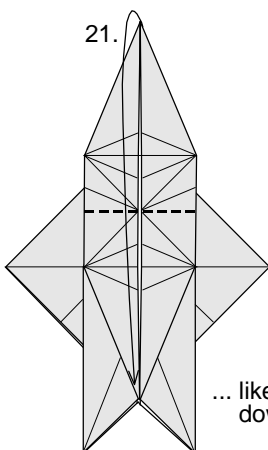

... like this, before bringing down the flap again.

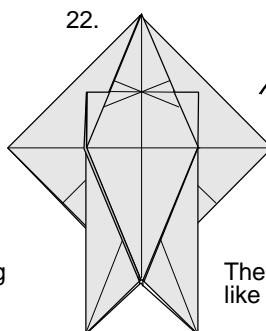

The model should now look like this. Turn the model over.

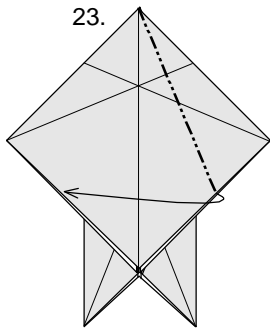

Repeat Step 15 on the right, and then on the left.

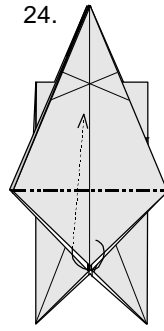

Mountain fold the triangular portion of the uppermost layer under and against itself.

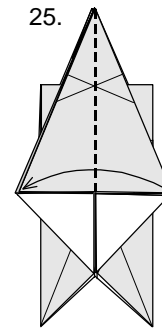

Fold the first flap on the right to the left.

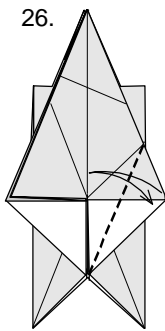

Fold and unfold, creasing firmly ...

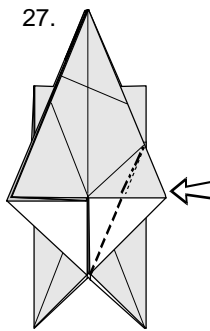

... then reverse fold.

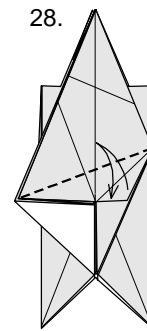

Fold and unfold again, from the left corner to the corner on the right.

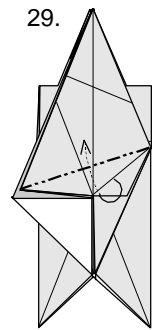

Now mountain fold the excess paper under as well ...

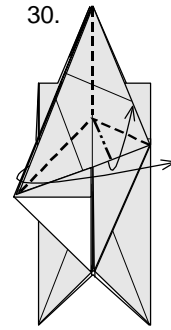

... then close up with a rabbit's ear fold.

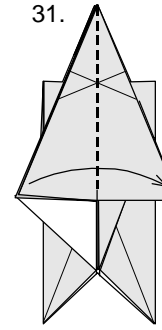

Fold the flap on the left to the right and repeat from Step 26 on the other side.

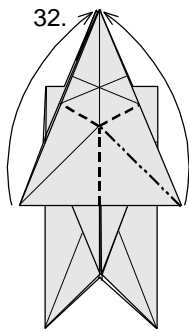

Bring the corners from the sides to the apex.

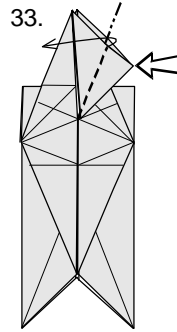

Squash fold ...

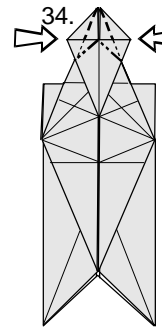

... and then petal fold, as you did in Steps 16 to 18.

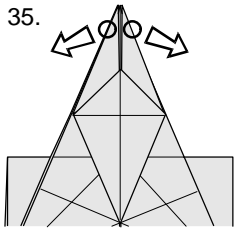

35. Grasp the flaps at the circled area and pull gently apart, ...

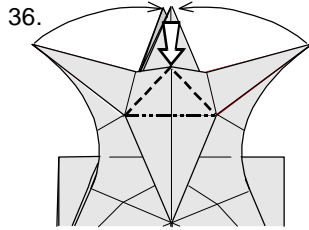

36. ... then reverse fold to hide the triangular tab beneath.

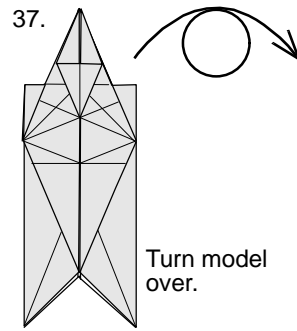

37. Turn model over.

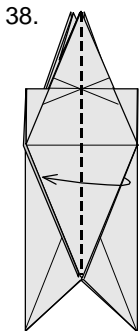

38. Swivel both layers to the left, ...

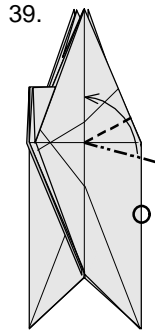

39. ... grasp the paper at the circled area and make a crimp fold while drawing the paper, slightly beyond midway, towards the top ...

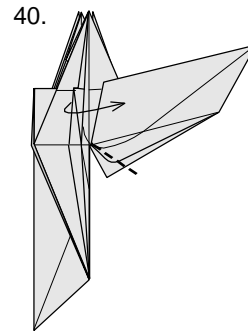

40. ... like this. Return the two layers folded in Step 38 to the right and flatten out.

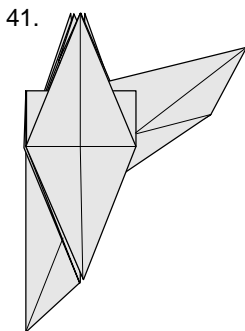

41. The model should now look like this. Repeat Steps 38 to 40 on the left side of the model.

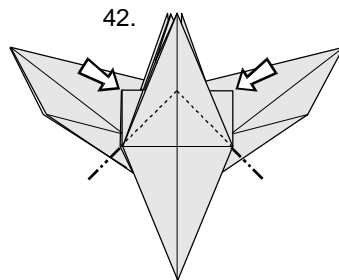

42. The pieces on each side, which will form the wings, should be symmetrical. Reverse fold each of the tabs on the sides ...

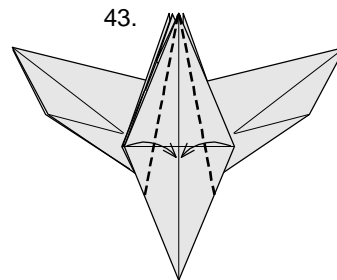

43. ... then valley fold the sides of the top layer to narrow.

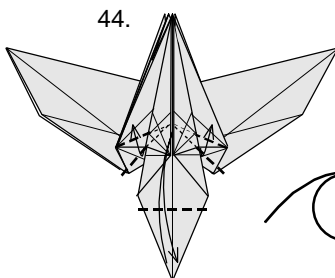

44. Valley fold the tail piece upwards, crease firmly, and unfold. Next crimp fold the layer at the base of each wing as illustrated, then turn model over.

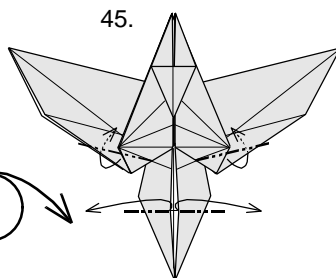

45. Mountain fold the first layer at the bottom corner of the wings within itself, then separate and draw the central vertical edges of the tailpiece to the sides ...

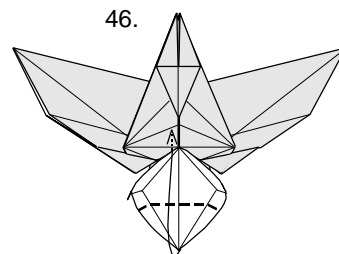

46. ... and reverse fold to hide the lower portion of the tailpiece within the opening ...

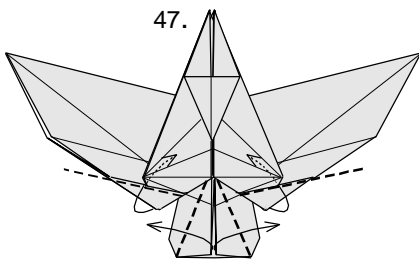

... like this. Now valley fold the corners of the second layer of the wing within itself, and widen the tail by folding out the overlapping tabs in the middle.

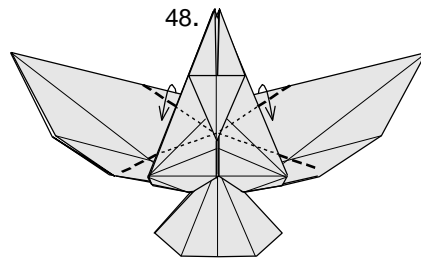

Crimp fold the front of the wings as illustrated.

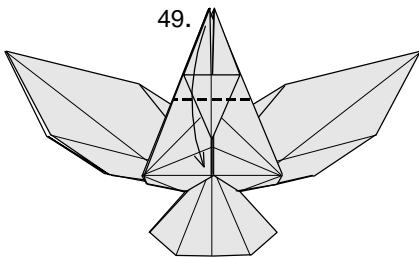

Bring down the uppermost flap with a valley fold, ...

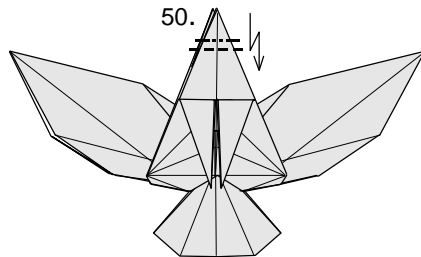

... crimp fold through all remaining layers at the top to form the head ...

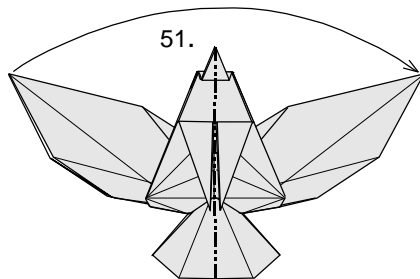

... and mountain fold the model vertically in half

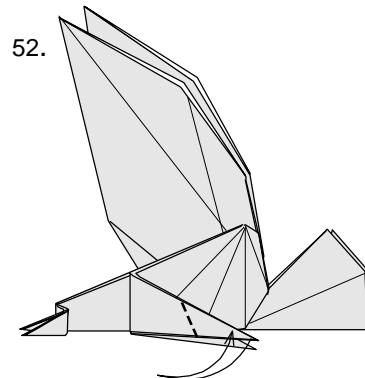

Now to form the left claw. First, fold and unfold ...

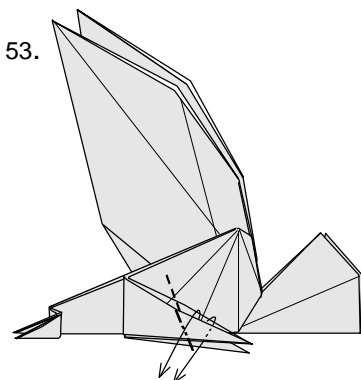

... then do an outside reverse fold using the crease lines made in Step 52. You will need to open out the layers temporarily to do this.

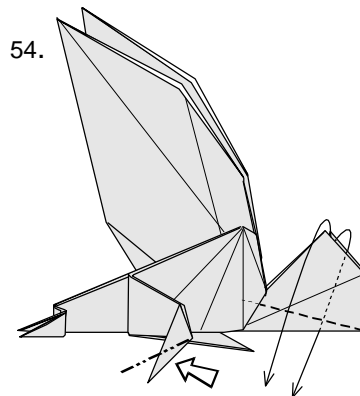

Inside reverse fold the claw, then outside reverse fold at the tail.

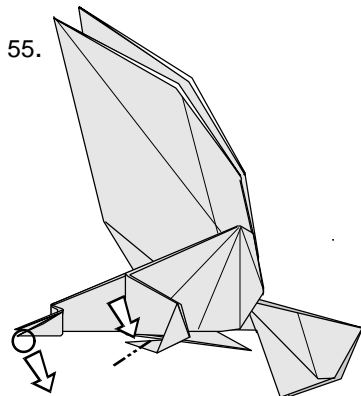

Pull down the lower beak just a little. Reverse fold the tip of the left claw once more as illustrated, then repeat from Step 52 on the right claw.

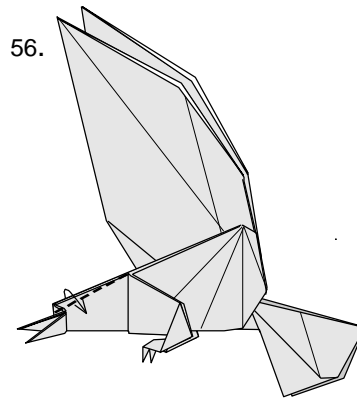

Valley fold both sides of the head and neck area as illustrated.

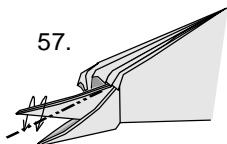

Outside reverse fold the tip of the beak ...

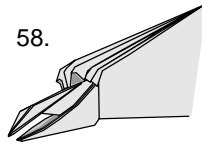

... like this.

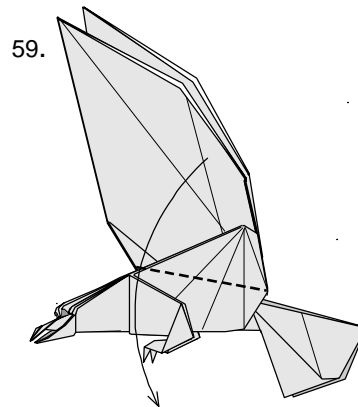

Fold down the wing on this side ...

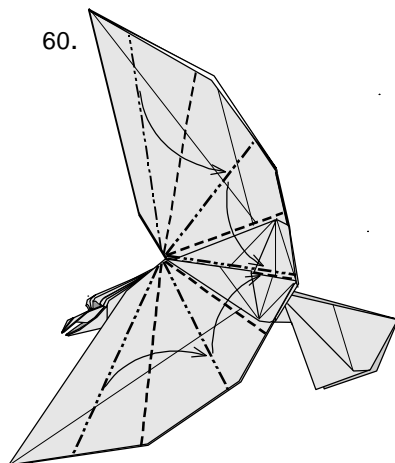

... then crimp the wing with a series of mountain and valley folds as illustrated. Repeat from Step 59 on the other wing.

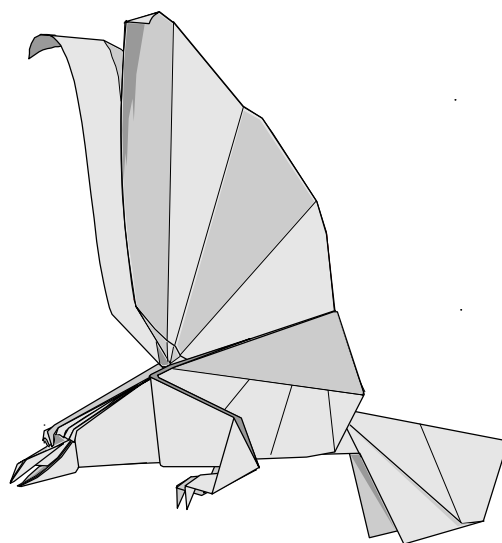

Finally, spread out and curve the wings for greater realism.